

## UNIT I

### FEEDBACK AMPLIFIERS

#### 1. State the nyquist criterion to maintain the stability of negative feedback amplifier(APR/MAY 2015)

The nyquist criterion forms the basis of a steady state method of determining whether an amplifier is stable or not.

##### Nyquist Criterion

The  $A\beta$  is a function of frequency. Points in the complex plane are obtained for the values of  $A\beta$  corresponding to all values of 'f' from  $-\infty$  to  $\infty$ . The locus of all these points forms a closed curve.

The criterion of nyquist is that amplifier is unstable if this curve encloses the point  $(-1+j0)$ , and

the amplifier is stable if the curve does not enclose this point.

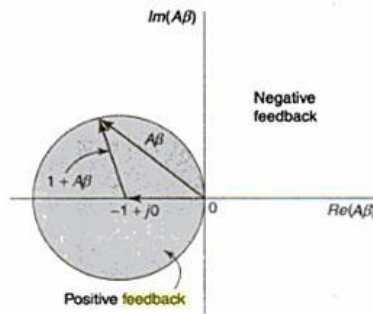

FIG. locus of  $|1+A\beta|=1$

#### 2. Define sensitivity and desensitivity of gain in feedback amplifiers.(April/May 2011)

**Sensitivity** :The fractional change in amplification with feedback divided by the fractional change in amplification with out feedback is called the sensitivity of the transfer gain.

$$\text{sensitivity} = \frac{\left| \frac{dA_f}{A_f} \right|}{\left| \frac{dA}{A} \right|} = \frac{1}{1 + A\beta}$$

**Desensitivity**: Desensitivity is defined as the reciprocal of sensitivity. It indicates the factor by which the voltage gain has been reduced due to feedback network.

$$\text{Desensitivity factor (D)} = 1 + A\beta.$$

Where A = Amplifier gain.

$\beta$  = Feedback factor.

#### 3. A feedback amplifier has an open loop gain of 600 and feedback factor $\beta = 0.01$ . Find the closed loop gain with feedback.

$$\begin{aligned} A_{vf} &= A_v / (1 + A_v \beta) \\ &= 600 / (1 + 600 * 0.01) \\ &= 85.714. \end{aligned}$$

#### 4. The distortion in an amplifier is found to be 3%, when the feedback ratio of negative feedback amplifier is 0.04. When the feedback is removed, the distortion becomes 15%. Find the open and closed loop gain.

Given:  $\beta = 0.04$

Distortion with feedback = 3%,

Distortion without feedback = 15%

$$D = 15/3 = 5.$$

$$\text{Where } D = 1 + A\beta = 5$$

**5. Voltage gain of an amplifier without feedback is 60dB. It decreases to 40dB with feedback. Calculate the feedback factor.**

Given:  $A_v = 60\text{dB}$  and  $A_{vf} = 40\text{ dB}$ .

We know that,

$$A_{vf} = A_v / (1 + A_v\beta)$$

$$\begin{aligned} \beta &= (A_v - A_{vf}) / (A_v A_{vf}) \\ &= (60 - 40) / (60 * 40) \\ \beta &= 0.00833. \end{aligned}$$

**6. What is the impact of negative feedback on noise in circuits?(MAY/JUNE 2016)**

When negative feedback is employed in an amplifier, the noise is reduced.

Let  $N$  = noise without feedback

$$N_f = \frac{N}{1 + A\beta} = BW(1 + A\beta)$$

$N_f$  = noise with feedback

The noise with feedback is given by the following relation —

From above equation it is clear that when the feedback is applied the noise is reduced by a factor  $(1 + A\beta)$

**7. Justify that negative feedback amplifier increases bandwidth. (Nov/Dec 2010)**

When negative feedback is employed in an amplifier, the bandwidth is increased. Let

$BW$  = bandwidth without feedback

$BW_f$  = bandwidth with feedback

The bandwidth with feedback is given by the following relation,

From above equation it is clear that when the feedback is applied the bandwidth is increased by a factor  $(1 + A\beta)$

**8. List the characteristics of an amplifier which are modified by negative feedback. (Nov/Dec 2013)**

- It increases the stability of an amplifier.
- It increases the bandwidth
- It decreases noise and distortion
- It reduces the gain of amplifier.

**9. Mention the three networks that are connected around the basic amplifier to implement the feedback concept. [NOV/DEC 2012]**

The three networks that are connected around the basic amplifier to implement the feedback concept are

- ✓ Mixing Network
- ✓ Sampling Network
- ✓ Feedback Network

**10. What happens to the input resistance based on the type of feedback in an amplifier? [MAY/JUNE 2009]**

- If the feedback signal is added to the input in **series** with the applied voltage, it **increases** the input resistance.
- -> If the feedback signal is added to the input in **shunt** with the applied voltage, it **decreases** the input resistance.

**11. What are the steps to be carried out for complete analysis of a feedback amplifier?  
[MAY/JUNE 2009]**

- Step 1 : Identify the topology
- Step 2,3: Find input and output circuit
- Step 4 : Replace transistor by its h-parameter equivalent circuit
- Step 5 : Find open loop voltage gain
- Step 6 : Indicate  $V_0$  and  $V_f$  and calculate  $\beta$
- Step 7 : Calculate  $D$ ,  $A_{vf}$ ,  $R_{if}$ ,  $R_{of}$  and  $R_{of}$

**12.State the effect on input and output resistance of amplifier on voltage series negative feedback is employed. (May/June 2013)**

Characteristics	Type of feedback			
	Current-series	Voltage-series	Voltage-shunt	Current-shunt
Voltage gain	Decreases	Decreases	Decreases	Decreases
Bandwidth	Increases	Increases	Increases	Increases
Input resistance	Increases	Increases	Decreases	Decreases
Output resistance	Increases	Decreases	Decreases	Increases

**13.What is return ratio of a feedback amplifier.(Nov/Dec 2011)**

The difference signal  $X_d = X_i - X_f$  is multiplied by gain  $A$  in passing through the amplifier, is multiplied by  $\beta$  in transmission through the feedback network and is multiplied by  $-1$  in the mixing network. Such a path takes from the input terminated around the loop consisting of amplifier and feedback network back to the input. The product  $-A\beta$  is called return ratio of the feedback amplifier.

**UNIT II**  
**OSCILLATORS**

**1. Mention two essential conditions for a circuit to maintain oscillations [MAY/JUNE 2012, NOV/DEC 2011, and APRIL/MAY 2010. NOV/DEC 2006, APR/MAY 2015]**

The conditions for oscillator to produce oscillation are given by Barkhausen criterion. They are

- i) The total phase shift produced by the circuit should be  $360^\circ$  or  $0^\circ$
- ii) The Magnitude of loop gain must be greater than or equal to 1 (ie)  $|A\beta| \geq 1$

**2. What is the major disadvantage of a Twin-T oscillator? [NOV/DEC 2012]**

Twin –T oscillator is operated only at one frequency.

**3. State Barkhausen criterion for sustained oscillation. What will happen to the oscillation if the magnitude of the loop gain is greater than unity? [NOV/DEC 2013]**

The conditions for oscillator to produce oscillation are given by Barkhausen criterion. They are :

- i) The total phase shift produced by the circuit should be  $360^\circ$  or  $0^\circ$
- ii) The Magnitude of loop gain must be greater than or equal to 1 (ie)  $|A\beta| \geq 1$

In practice loop gain is kept slightly greater than unity to ensure that oscillator work even if there is a slight change in the circuit parameters.

**4. Why an LC tank circuit does not produce sustained oscillations. How can this can be overcome? [NOV/DEC 2008]**

We know that the inductor coil has some resistance and dielectric material of the capacitor has some leakage. so small part of the originally imparted energy is used to overcome these losses. As a result, the amplitude of oscillating current goes on decreasing and becomes zero when all energy is consumed as losses. So a LC tank circuit does not produce sustained oscillations.

To maintain sustained oscillations, energy must be supplied to the circuit at the same rate at which it is dissipated. In an oscillator, the function of transistor and power supply source is to feed energy to the circuit to overcome the losses at right time.

**5. Draw the electrical equivalent circuit of crystal. [NOV/DEC 2013, NOV/DEC 2006, MAY/JUNE 2007] and mention its series and parallel resonance frequency. [NOV/DEC 2006, MAY/JUNE 2007, APR/MAY 2008]**

The crystal actually behaves as a series RLC circuit in parallel with  $C_M$ . Because of presence of  $C_M$ , the crystal has two resonant frequencies.

- One of these is the series resonant frequency  $f_s$ . In this case impedance is very low.

$$f_s = \frac{1}{2\pi\sqrt{LC}}$$

- The other is parallel resonance frequency  $f_p$ . In this case impedance is very high.

$$f_p = \frac{1}{2\pi\sqrt{LC_{\text{eq}}}}, \text{ where } C_{\text{eq}} = \frac{CC_M}{C + C_M}$$

**6. What are the advantages and disadvantages of RC phase shift oscillators? [APR/MAY 2008, MAY/JUNE 2016]**

**Advantages:**

- i. It is best suited for generating fixed frequency signals in the audio frequency range.
- ii. It requires no transformer or inductor, hence less bulky.
- iii. Simple Circuit.

\*Pure sine wave output is possible.

**Disadvantages:**

- i) It requires a high  $\beta$  transistor to overcome losses in the network.
- ii) These oscillators are not suitable for high frequency operation.
- iii) Frequency of oscillation can not be changed easily. To change the frequency of oscillation, the three capacitor or resistors should be changed simultaneously. This is inconvenient.

**7. What is the necessary condition for a Wien bridge oscillator circuit to have sustained oscillations? [MAY/JUNE 2013]**

Then for oscillations to occur in a **Wien Bridge Oscillator** circuit the following conditions must apply.

- ✓ With no input signal the Wien Bridge Oscillator produces output oscillations.
- ✓ The Wien Bridge Oscillator can produce a large range of frequencies.
- ✓ The Voltage gain of the amplifier must be at least 3.
- ✓ The network can be used with a Non-inverting amplifier.
- ✓ The input resistance of the amplifier must be high compared to R so that the RC network is not overloaded and alter the required conditions.
- ✓ The output resistance of the amplifier must be low so that the effect of external loading is minimised.

**8. Define piezoelectric effect. [MAY/JUNE 2006]**

The piezo electric Crystals exhibit a property that if a mechanical stress is applied across one face the electric potential is developed across opposite face and viceversa. This phenomenon is called piezo electric effect.

**9. What is the principle behind operation of a crystal oscillator? [NOV/DEC 2007]**

The principle behind the operation of crystal is piezoelectric effect. According to this effect, if a mechanical stress is applied across one face the electric potential is developed across opposite face and viceversa.

**10. Draw an oscillator circuit with feedback network given below. [MAY/JUNE 2006]**

Wien Bridge Oscillator Circuit

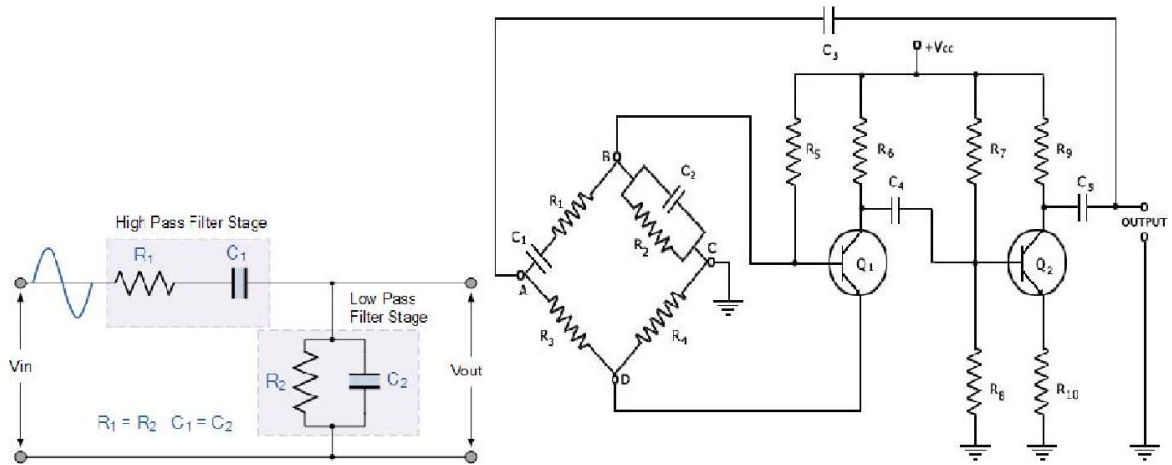

## UNIT –III

### TUNED AMPLIFIERS

#### 1. What is tuned amplifier? What are the various types of tuned amplifiers?[NOV/DEC 2013]

A tuned amplifier amplifies a certain range of frequencies (narrow band of frequencies) in the radio frequency region and rejects all other frequencies.

##### Types:

The various types of tuned amplifiers are

- i) Single tuned amplifier
- ii) Double tuned amplifier
- iii) Stagger tuned amplifier & synchronously tuned amplifier.

#### 2. Define tuned amplifier.[APRIL/MAY 2010]

A tuned amplifier is defined as an amplifier circuit which amplifies a certain range of frequencies (narrow band of frequencies) in the radio frequency region and reject all other frequencies.

#### 3. Mention The Two Applications of tuned amplifiers.[ NOV/DEC 2007, NOV/DEC 2008]

- i) They are used in IF amplifiers in Radio and TV receivers.
- ii) They are used in wireless communication systems.

#### 4. State two advantages and two disadvantages of tuned amplifiers. [MAY/JUNE 2012]

##### Advantages:

- i) They amplify defined frequencies
- ii) Signal to noise ratio (SNR) at output is good.
- iii) They are suited for radio transmitters and receivers.

##### Disadvantages:

- i) They are not suitable to amplify audio frequencies.
- ii) Circuit is bulky and costly.
- iii) The design is complex.

#### 5. What are the differences between single tuned and synchronously tuned amplifiers?[NOV/DEC 2007]

Single tuned amplifier	Synchronously tuned amplifier
<ul style="list-style-type: none"><li>• Uses one parallel tuned circuit as the load impedance and tuned to one frequency.</li><li>• High gain and narrow bandwidth</li><li>• Bandwidth is</li></ul> $BW = \frac{f_r}{Q}$	<ul style="list-style-type: none"><li>• Uses a number of identical cascaded single tuned stages tuned to same frequency.</li><li>• Increases gain and reduces bandwidth.</li><li>• The bandwidth equation is</li></ul> $BW_n = BW_1 \sqrt{2^{1/n} - 1}$

### 6. What is Stagger tuned amplifier[NOV/DEC 2011]

If two or more tuned circuits which are cascaded are tuned to slightly different resonant frequencies, it is possible to obtain an increased bandwidth with a flat passband with steep sides. This technique is known as stagger tuning and the amplifier using this technique is called as stagger tuned amplifier.

### 7. Why neutralization required in tuned amplifiers?[NOV/DEC 2013,NOV/DEC 2010]& Draw the circuit for Narrow Band neutralization.[NOV/DEC 2010]

In order to prevent oscillations in tuned RF amplifiers it was necessary to reduce the stage gain to a level that ensured circuit stability. This can be accomplished in several ways such as lowering the Q of the tuned circuits, stagger tuning, loose coupling between the stages. Instead of losing the circuit performance to achieve stability, a circuit in which the troublesome effect of the collector to base capacitance of the transistor was neutralised by introducing a signal which cancels the signal coupled through the collector to base capacitance

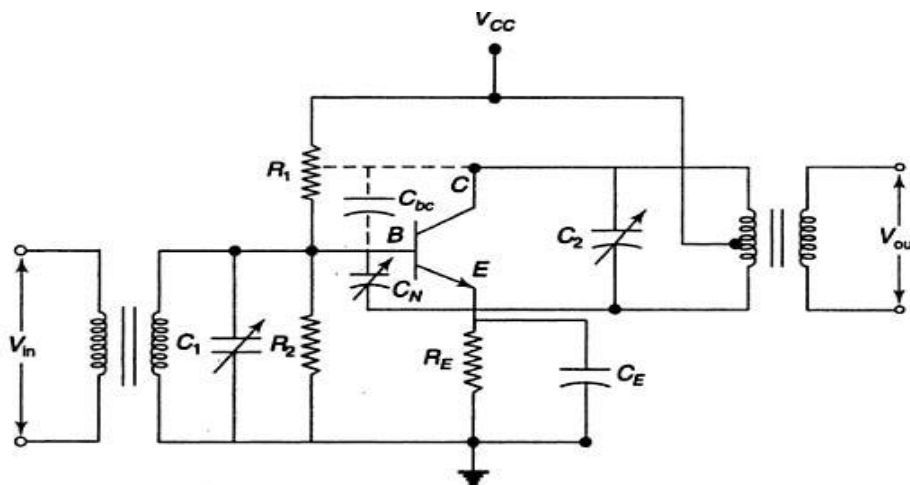

Fig. 13.30 Tuned RF amplifier with Hazeltine neutralization ( $C_N$  = neutralization capacitance)

### 8. Define loaded and unloaded Q.[NOV/DEC 2010, APRIL/MAY 2010]

#### Unloaded Q:

It is defined as the ratio of stored energy to dissipated energy in a reactor or resonator. For an inductor or capacitor

$$Q_u = \frac{X}{R_s}$$

Where X= reactance:  $R_s$ = series resistance

#### Loaded Q:

The loaded Q or  $Q_L$  of a resonator is determined by how tightly the resonator is coupled to its terminations.

$$Q_L = 2\pi \times \frac{\text{Maximum energy stored per cycle}}{\text{Energy dissipated per cycle} + \text{Energy dissipated due to external load}}$$



**9. What is the effect of cascading n stages of identical single tuned amplifiers (synchronously tuned) on the overall 3db bandwidth?[APRIL/MAY 2011]**

The bandwidth of n stage cascaded single tuned amplifier is given as

$$BW_n = BW_1 \sqrt{2^{1/n} - 1}$$

From the above equation it is clear that the overall 3dB bandwidth reduces.

**10. Where is the Q-point placed in a class C type amplifier? What are its applications?[APR/MAY 2008]**

In a class C type amplifier the Q-point is placed below the X-axis.

**Applications:**

- The Class C amplifiers are used to amplify the signals at radio frequencies.
- They are also used in mixer circuits.

**11. Brief the relation between bandwidth and Q-factor.[ MAY/JUNE 2007]**

The quality factor determines the 3dB bandwidth for the resonant circuit. The 3dB bandwidth for resonant circuit is given by

$$BW = \frac{f_r}{Q}$$

Where  $f_r$  = centre frequency of a resonator

$$BW = f_2 - f_1$$

If Q is large bandwidth is small.

If Q is small bandwidth is large.

**12. What is narrow band neutralization? [APR/MAY 2008, APRIL/MAY 2011, NOV/DEC 2012]**

The process of cancelling the instability effect due to the collector to base capacitance of the transistor in tuned circuits by introducing a signal which cancels the signal coupled through the collector to base capacitance is called narrow band neutralization.

**13. Mention two important features of stagger tuned amplifier. [MAY/JUNE 2013]**

- i) It has better flat, wide band characteristics.
- ii) Increased bandwidth

**14. What is the need for neutralization circuits? [MAY/JUNE 2013, NOV/DEC 2008, MAY/JUNE 2014]**

In tuned RF amplifiers, the inter-junction capacitance  $C_{bc}$  of the transistor becomes dominant (i.e) its reactance is low, it provides the feedback signal from collector to base. If some feedback signal manages to reach the input from output in a positive manner with proper phase shift, then amplifier keeps oscillating, thus stability of amplifier gets affected. Hence neutralization is employed.

**15. Draw a class C tuned amplifier circuit and what is its efficiency.[ MAY/JUNE 2006]**

$$\eta = \frac{P_{out}}{P_s} \times 100\%$$

At conduction angle  $\theta = 180^\circ$ ,  $\eta = 78.5\%$

## UNIT IV

### WAVE SHAPING CIRCUITS AND MULTIVIBRATORS

#### **1. Give two applications of bistable multivibrators(APRIL/MAY 2010,APRIL/MAY 2011)**

- Used to generate symmetrical square wave. This is possible by using triggering pulses of equal interval, corresponding to the frequency required.
- Used as a memory element in shift registers, counters, etc.,
- Used for the performance of many digital operations like counting and storing of digital information.
- Can be used as a frequency divider

#### **2. How does a diode act as a comparator?(NOV/DEC 2010)**

A Comparator Circuit is used to identify the instant at which the arbitrary input waveform attains a particular reference level. Basically it is a clipper circuit. A simple diode comparator and its equivalent circuit is given as

Consider  $V_{in}$  as a ramp input, increasing linearly from zero. The output will remain at  $V_R$ , till input is less than  $V_R + V_Y$ , as the diode is not conducting. (ie)  $V_o = V_R$  for  $V_{in} < V_R + V_Y$

At  $t = t_1$ ,  $V_{in}$  becomes equal to  $V_R + V_Y$ , after which  $V_o$  increases alongwith the input signal  $V_{in}$ .

The comparator output is given to a particular device. This device will respond when the comparator voltage increases to some level of  $V_o$  above  $V_R$ .

#### **3. What is meant by clipper circuit?(APRIL/MAY 2011)**

The electronic circuits which are used to clip off the unwanted portion of the waveform, without distorting the remaining part of the waveform are called clipper circuits.

#### **4. What is the 'tilt' applicable to RC circuits? Give an expression for tilt. (NOV/DEC 2011)**

In high pass RC network, Tilt is defined as the decay in the amplitude of the output voltage waveform, when the input maintains its level constant.

Percentage of tilt is given by

$$P = \frac{V - V'}{V/2} \times 100$$

Therefore

$$P = \frac{T}{2RC} \times 100\%$$

Where T- time period

**5. What type of distortion is observed in astable multivibrator?(NOV/DEC 2011)**

It can be seen that, in the collector waveforms shown in the figure there is certain distortion present. Instead of  $[V_{c1}, V_{c2}]$  exact square wave, we are getting the vertical rising edges little bit rounded. This is called **rounding**. For a square wave output such a rounding is undesirable and must be eliminated.

**6. What is meant by clamper circuit?(MAY/JUNE 2012,NOV/DEC 2009)**

The electronic circuits which are used to add a dc level as per the requirement to the ac output signal are called clamper circuits.

It is also known as dc inserter or dc restorer.

**7. Give two applications of Schmitt Trigger circuit. (MAY/JUNE 2012).**

- It is used as a amplitude comparator
- It can be used as a squaring circuit.
- It can be used as a sine wave to square wave converter

**8. Why do we call astable multivibrator as free running multivibrator?(NOV/DEC 2012)**

An astable multivibrator is called free running multivibrator because it generates square waves of its own without any external triggering pulse.

**9. Define the threshold points in a Schmitt trigger circuit.(NOV/DEC 2013)**

- Schmitt trigger is a type of comparator with two different threshold voltage levels on points (UTP, LTP).
- Whenever the input signal goes over the high threshold levels, the output of the comparator is switched high. The output will remain in this same state as long as the input voltage is above the low threshold level.
- When the input voltage goes below this level, the output will switch. These threshold voltage levels are called threshold points.

**10. What is a regenerative comparator? Give example circuit.(MAY/JUNE 2013)**

Regenerative comparator is a circuit, compares its input voltage to a “threshold voltage”, because it has two threshold voltages(the upper and lower trigger voltages). The threshold voltage depends on the output state. If the input voltage is higher than the upper trigger voltage, the output will be high.

A small amount of the output voltage is effectively added to the input voltage before it is compared to a fixed threshold. So it uses positive (or) regenerative feedback.

E.g.: Schmitt Trigger

**11. Distinguish between symmetrical and unsymmetrical triggering methods.[NOV/DEC 2009]**

Symmetrical triggering uses only one trigger input and unsymmetrical triggering uses two trigger input.

**12. Why Monostable multivibrator is also called as delay circuit?[MAY/JUNE 2009]**

Used to introduce time delay as gate width is adjustable.

## UNIT V

### BLOCKING OSCILLATORS AND TIMEBASE GENERATOR

**1. Sketch & Define slope error and displacement error.(MAY/JUNE 2013, April/MAY 2011, NOV/DEC 2011,MAY/JUNE 2009)**

**Slope error (or) sweep speed error ( $e_s$ ):**

Slope error is defined as the ratio of the difference in slope at beginning and end sweep to the initial value of the slope. It is also called as sweep speed error( $e_s$ )

$$e_s = \frac{\text{Difference in slope at beginning and end of sweep}}{\text{initial value of slope}}$$

**Displacement Error( $e_d$ ):**

It is defined as the maximum difference between the actual sweep voltage and linear sweep which passes through the beginning and end points of the actual sweep.

The displacement error is given as

$$e_d = \frac{(V_s - V'_s)_{\max}}{V_s}$$

**2. Mention two applications of blocking oscillators.(MAY/JUNE 2013,APRIL/MAY 2011,NOV/DEC 2010,MAY/JUNE 2009)**

- ✓ Used as a main device to supply triggers for synchronization of a system having pulse type waveforms
- ✓ Used as a Frequency Divider or Counter
- ✓ Used to produce large peak power pulses.
- ✓ As a low impedance switch

**3. State any two applications of pulse transformer.(MAY/JUNE 2012)**

- To act as a coupling element in certain pulse generating circuits such as blocking oscillators
- To invert the polarity of pulse
- To provide dc isolation between source and a load
- To produce pulse in a circuit having negligible dc resistance
- To differentiate a pulse

**4. What are 'Restoration time' and 'Sweep time' of a time base signal?(MAY/JUNE 2012)**

**Restoration time ( $T_r$ ):**

It is the time required for the return to its initial value. It is also called as **return time** or **flyback time**.

**Sweep time( $T_s$ ):**

It is the period during which voltage increases linearly

**5. List the applications of time base generators.(NOV/DEC 2013)**

- Used in CRO(Cathode Ray Oscilloscope)
- Used in Television and radar displays
- Used in precise time measurements
- Used in time modulation

**6. What are the advantages of core saturation method of frequency control in a blocking oscillator?(NOV/DEC 2012)**

The pulse duration depends on the supply voltage and characteristics of the core and not on the transistor parameters ( $h_{fe}$ ).

The pulse width is given by

$$t_p = \frac{(n + 1)NAB_{121}}{V_{cc}}$$

**7. State any two methods of achieving sweep linearity of a time-base waveform.(NOV/DEC2012)**

- ✓ Exponential charging
- ✓ Constant current charging
- ✓ Miller circuit
- ✓ Bootstrap circuit.

**8. What is the function of time base circuit?(APRIL/MAY 2010)**

A linear time base generator produces an output waveform, which produces a portion which exhibits a linear variation of voltage or current with respect to time.

**9. What is pulse transformer?[APR-2004]**

A pulse transformer is basically a transformer which couples a source of pulses of electrical energy to the load, keeping the shape and other properties of pulses unchanged. The voltage level of the pulse can be raised or lowered by designing the proper turns ratio for the pulse transformer.

**10. Define Blocking Oscillator? What are its elements? State its applications?(MAY/JUNE 2016)**

A special type of wave generator which is used to produce a single narrow pulse or train of pulses. Applications are..

Transistor and pulse transformer-important elements

It is used in frequency dividers, counter circuits and for switching the other circuits.